

FSHR40-12 & FSHR40-24

25Kg Door Holder, Wall Mount



Features

- Fire Rated
- Up to 25kg Holding Force
- 12 & 24V DC Options
- Fail Safe Operation

FSHR40-12 & FSHR40-24



Product Dimensions & Installation

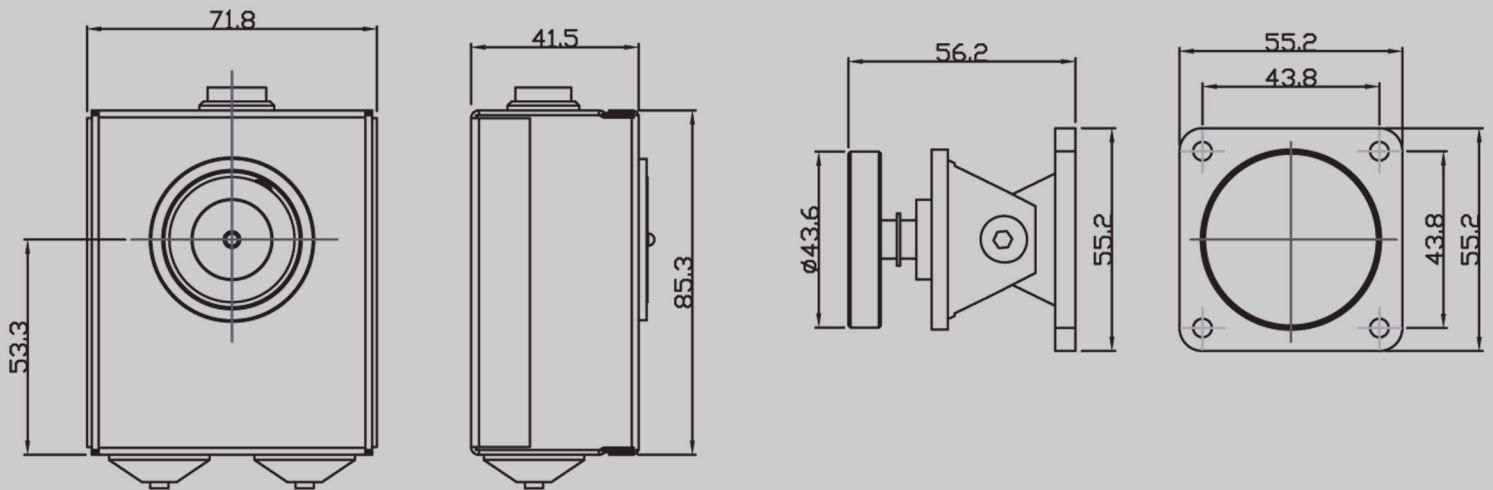

Product Specifications

PART NO.	R40-12(12Volt)	R40-24(24Volt)
FUNCTION	Wall mount electro magnetic door holder for fire and smoke doors	
HOLDING STRENGTH	Up to 25kg	
VOLTAGE/CURRENT	12VDC/160mA 24VDC/80mA	
SIZE	D= 41.5 x W= 71.8 x H= 85.3	